



Department
for Education



Education
Funding
Agency

Acoustic design of schools: performance standards

Building Bulletin 93

December 2014

Contents

Summary	5
About this publication	5
Acknowledgements	5
Disclaimer	5
Expiry/review date	5
Who is this advice for?	5
Key points	5
Definitions	6
School client body	6
0. Introduction and Scope	7
0.1. Background	7
0.2. Regulatory framework	7
0.2.1. Building Regulations	7
0.2.2. School Premises Regulations and Independent School Standards	8
0.2.3. Equality Act 2010	8
0.3. Areas covered by the regulations	8
0.3.1. Teaching and non-teaching spaces	8
0.3.2. Temporary buildings	9
0.3.3. New-build, conversion and refurbishment work	9
0.3.3.1. Material changes of use	9
0.3.4. Nursery and community education	10
0.3.5. Sixth-form colleges, universities and colleges of further education	10
0.3.6. When do the regulations apply?	11
0.3.7. Planning issues	12
0.3.8. Performance in use	12
0.4. Provision for children having special hearing or communication needs	12
0.4.1. Special school accommodation and special units attached to mainstream schools	13
0.5. Alternative performance standards	14
0.6. Surface spread of flame rating of acoustic linings and absorbers	14

0.7. Durability and robustness	15
0.8. Acoustics and ventilation	15
1. Performance standards	16
1.1. Indoor ambient noise levels in unoccupied spaces	17
1.1.1. Objectives and definitions	17
1.1.2. Acoustic performance standards	17
1.1.3. Building services and indoor ambient noise levels	20
1.1.4. Noise from ventilator actuators and dampers	24
1.2. Airborne sound insulation between spaces	25
1.2.1. Objectives and definitions	25
1.2.2. Acoustic performance standards	25
1.2.3. Exceptions	26
1.3. Airborne sound insulation between circulation spaces and other spaces used by students	26
1.3.1. Objectives and definitions	26
1.3.2. Acoustic performance standards	27
1.4. Impact sound insulation of floors	28
1.4.1. Objectives and definitions	28
1.4.2. Acoustic performance standards	29
1.4.3. Exceptions	31
1.5. Reverberation in teaching and study spaces	31
1.5.1. Objectives and definitions	31
1.5.2. Acoustic performance standards	31
1.6. Reverberation and acoustic absorption in sports halls and swimming pools	33
1.6.1. Objectives and definitions	33
1.6.2. Acoustic performance standards	34
1.6.3. Demonstrating compliance	34
1.7. Sound absorption in corridors and stairwells	34
1.7.1. Objectives and definitions	34
1.8. Open plan teaching and learning	35
1.8.1. Objectives and definitions	35
1.8.2. Acoustic performance standards	36

1.8.3. Exceptions	37
1.8.4. Demonstrating compliance	37
2. Compliance	38
2.1. Procedures	38
2.2. Alternative performance standards	38
2.3. Acoustic commissioning	38
References	39
Further information	40
Useful resources and external organisations	40
Other relevant departmental advice and statutory guidance	40
Other departmental resources	40

Summary

About this publication

This document supersedes section 1 of 'Building Bulletin 93' (BB93) published in 2003. It sets out minimum performance standards for the acoustics of school buildings, and describes the normal means of demonstrating compliance with the Building Regulations. It also provides guidance in support of the School Premises Regulations (2012) and the Independent School Standards (2013).

Acknowledgements

The Department for Education (DfE) would like to thank the Schools Committee of the Association of Noise Consultants and the Institute of Acoustics for their help in drafting this document.

Disclaimer

DfE and its advisers accept no liability whatsoever for any expense, liability, loss, claim or proceedings arising from reliance placed upon this document.

Expiry/review date

This advice will next be reviewed in 2019.

Who is this advice for?

This advice is for all those involved in the specification, design and construction of school buildings.

Key points

The overall objective of the performance standards is to ensure that the design and construction of school buildings provide acoustic conditions that enable effective teaching and learning.

Definitions

School client body

The school client body consists of both the commissioning authority and the school entity. The school entity has day to day control of the school and may be represented by the headteacher or a governor. The commissioning authority is the authority that commissions the work: central government, a local authority or the school itself.

0. Introduction and Scope

0.1. Background

This document should be read in conjunction with ‘Acoustics of schools: a design guide’ [Ref.1](#), published by the Association of Noise Consultants and the Institute of Acoustics, which contains supporting information and additional design considerations. References to the guide are made throughout this document. On publication, the guide will supersede sections 2 to 7 of [Building Bulletin 93 \(2003\)](#) [Ref.2](#).

[Section 1](#) of this document sets out the acoustic performance standards. The normal way of satisfying Requirement E4 of the [Building Regulations](#) [Ref.3](#), the [School Premises Regulations](#) [Ref.4](#) and the [Independent School Standards](#) [Ref.5](#) is to meet the appropriate performance standards in section 1.

[Section 2](#) of this document sets out the preferred means for demonstrating compliance of the design to Education Funding Agency (EFA) or other school client body.

The school design will need to take into account other environmental needs of the pupils such as thermal comfort, indoor air quality, infection control, ample surfaces for display materials and easy access to outside areas.

0.2. Regulatory framework

The acoustic conditions in schools are controlled by Part E of the Building Regulations, School Premises Regulations and the Independent School Standards, which apply to new and existing schools. School premises are also subject to the [Equality Act](#) [Ref.6](#).

0.2.1. Building Regulations

Requirement E4 from Part E of Schedule 1 to the Building Regulations 2010 (as amended by Statutory Instrument, SI 2002/2871) states:

“Each room or other space in a school building shall be designed and constructed in such a way that it has the acoustic conditions and the insulation against disturbance by noise appropriate to its intended use.”

Approved Document E [Ref.3](#) in support of the Building Regulations gives the following guidance:

“In the Secretary of State’s view the normal way of satisfying Requirement E4 will be to meet the values for sound insulation, reverberation time and internal ambient noise which are given in section 1 of Building Bulletin 93 ‘The Acoustic Design of Schools’, produced by DfES.”

Note: Department for Education and Skills (DfES) is now DfE).

0.2.2. School Premises Regulations and Independent School Standards

The School Premises Regulations and Independent School Standards applies to both new and existing school buildings and contain a similar statement to that in Requirement E4 of the Building Regulations:

“The acoustic conditions and sound insulation of each room or other space must be suitable, having regard to the nature of the activities which normally take place therein.”

In addition to the design and construction standards covered by the Building Regulations, the School Premises Regulations and Independent School Standards cover the performance in use of schools including speech intelligibility in the classrooms. This means that in order to comply with the School Premises Regulations and the Independent School Standards (but not the Building Regulations), operational noise levels (eg of equipment) in teaching and learning spaces will need to be suitable for the activities taking place and open plan teaching and learning spaces in new and refurbished schools will need to provide adequate speech intelligibility as measured by the speech transmission index (STI).

School client bodies are responsible for ensuring compliance with the School Premises Regulations.

The School Premises Regulations and Independent School Standards do not apply retrospectively.

0.2.3. Equality Act 2010

The Equality Act 2010 replaces all previous equality legislation such as the Race Relations Act, Disability Discrimination Act and Sex Discrimination Act and provides a single, consolidated source of discrimination law, covering all the types of discrimination that are unlawful. It simplifies the law and extends the protection from discrimination in certain areas. The aspects that are relevant to acoustics in schools are principally those relating to disabilities, and where English is not the first language and clarity of speech is particularly important to assist comprehension.

0.3. Areas covered by the regulations

0.3.1. Teaching and non-teaching spaces

Requirement E4 of the Building Regulations applies to teaching and learning spaces. The School Premises Regulations and the Independent School Standards apply to all areas of schools. The Building Regulations are not intended to cover the acoustic conditions in administration and ancillary spaces not used for teaching and learning except where they affect conditions in neighbouring teaching and learning spaces, but do require consideration to be given to adjoining areas, such as corridors, which might have doors, ventilators, or glazing separating them from a teaching or learning space.

0.3.2. Temporary buildings

Buildings that are in place for 28 days or less are exempt from the Building Regulations including Requirement E4 but not from the School Premises Regulations and the Independent School Standards. New school buildings and extensions with a site life of more than 28 days should comply with all applicable Building Regulations including Requirement E4. Many buildings in schools have only temporary planning permission, which usually lasts for 2 years. These buildings are subject to the Building Regulations.

Additional guidance on prefabricated buildings is given in Clause 0.6 of Approved Document E. Prefabricated buildings include, for example, a building created by dismantling, transporting and re-erecting sub-assemblies on the same premises or another premises. In these circumstances by virtue of the School Premises Regulations, the minimum standards for refurbishment and conversion of existing buildings apply.

0.3.3. New-build, conversion and refurbishment work

The School Premises Regulations and the Independent School Standards apply to refurbishment work, and the acoustic standards for refurbishment works given in this document apply. Where there is a need to upgrade the acoustic performance of an existing building or when refurbishment is undertaken for other reasons, then the refurbished elements should meet, as far as reasonably practicable, the acoustic performance given in these guidelines to satisfy the School Premises Regulations, the Independent School Standards and the Equality Act.

Although Building Regulations do not apply to all alteration and refurbishment work, it is desirable that such work should consider acoustics and incorporate upgrading of the acoustics as appropriate. In addition, Regulation 4 of the Building Regulations requires that any building work on an existing school should not make an existing requirement or contravention any worse than before building work was carried out.

In the case of existing buildings, Part E of the Building Regulations applies to material changes of use as defined in Building Regulations. The tables in section 1 give recommended values for both new buildings and for refurbished elements.

Where there is a material change of use as defined in the Building Regulations, such work should be carried out as is necessary to ensure that the building complies with Requirement E4 of the Building Regulations. In these cases, the 'refurbishment' criteria contained within this document apply. The School Premises Regulations and Independent School Standards apply whether or not there is a material change of use.

0.3.3.1. Material changes of use

The Building Regulations apply to certain changes of use of an existing building known as 'material changes of use'.

The meaning of material change of use is given in Regulation 5 of the consolidated Building Regulations. For schools the most common material changes of use that are listed in Regulation 5 will be:

“5.(e) any building used as a public building, where previously it was not; and...

A “public building” is defined as a building consisting of or containing—

(b) a school or other educational establishment ...”

The Requirements of the Building Regulations relating to material change of use are given in Regulation 6.-(1):

“6.-(1) Where there is a material change of use of the whole of a building, such work, if any, shall be carried out as is necessary to ensure that the building complies with the applicable requirements of the following paragraphs of Schedule 1—“

0.3.4. Nursery and community education

Part E of the Building Regulations covers rooms used for nursery and adult/community education within school complexes but does not apply to nursery schools which are not part of a primary school.

The School Premises Regulations and Independent School Standards cover all types of schools, including nursery schools.

0.3.5. Sixth-form colleges, universities and colleges of further education

Part E4 of the Building Regulations and the School Premises Regulations do not cover sixth-form colleges that have not been established as schools. Part E of the Building Regulations quotes the definition of school given in Section 4 of the 1996 Education Act. In the case of sixth-form colleges Section 4 of the 1996 Act should be read in conjunction with Section 2 of the same Act, in particular subsections (2), (2A) and (4) which deal with the definition of secondary education.

If a sixth-form college is established as a school under the 1998 School Standards and Framework Act then it will be classed as a school under Section 4 of the 1996 Education Act and Part E of the Building Regulations on acoustics will apply.

Most sixth-form colleges are institutions in the further education sector and not schools, and Part E of the Building Regulations will not apply.

In the case of a new sixth-form college it will be necessary to contact the local authority to enquire if the sixth-form college has been established as a school or as an institute of further education. However, in the case of universities or colleges of further and higher education many of the acoustic specifications are desirable and can be used as a guide to

the design of these buildings. Part E4 does apply to sixth-form units forming part of a school.

0.3.6. When do the regulations apply?

Type of space	New build including extensions, pre-fab. buildings	Material change of use (from non-school building)	Refurbishment of existing school buildings including Material Alterations ⁴	Temporary buildings in place for up to 28 days ³
Schools ^{1, 2}	Building Regulation E4: applicable School Premises Regulations/Independent Schools Standards: applicable		Building Regulation E4: exempt School Premises Regulations/Independent Schools Standards: applicable	
Admin and ancillary areas	Building Regulation E4: exempt			
Nursery schools ² (not within school complexes)	School Premises Regulations/Independent Schools Standards: applicable			
Colleges/sixth-form colleges	Building Regulation E4: exempt School Premises Regulations/Independent Schools Standards: not applicable			
Higher education				
Further education				
Universities				
Community and adult education (not within school complexes)				

Notes

¹ 'Schools' includes independent schools, academies, free schools, university technical colleges, sixth-form colleges attached to schools, and nursery/community and adult education spaces within school complexes.

² School Premises Regulations apply to all schools, including community special schools and pupil referral units, which are treated as 'schools' in the table above.

³ Temporary buildings are those not intended to remain in place for longer than 28 days. All buildings that remain in place longer than 28 days must comply with the Building Regulations.

⁴ Regulation 4 of the Building Regulations requires that any building work on existing buildings should not make an existing condition any worse than before work was carried out.

0.3.7. Planning issues

Whilst planning consents should not be subject to conditions that are covered by other legislation, such as the Building Regulations, local planning authorities may include conditions relating to noise and acoustics when granting consent. These could cover such aspects as noise from schools affecting nearby noise sensitive properties, or educational establishments where the acoustic conditions are not subject to Requirement E4 of the Building Regulations. BREEAM Global currently refers to compliance with BB93 as a means of attaining specific BREEAM credits, verified by site testing in accordance with the Association of Noise Consultants 'Good Practice Guide – Acoustic Testing of Schools' [Ref.7](#) and compliance with a specific BREEAM rating may be a requirement for planning approval.

0.3.8. Performance in use

To comply with the School Premises Regulations and the Independent School Standards the operational noise (and maintenance) of classroom equipment should be considered, eg computers, projectors, fume cupboards etc. Further information on typical noise levels and good practice for design and operational noise can be found in 'Acoustics of schools :a Design Guide'[Ref.1](#).

0.4. Provision for children having special hearing or communication needs

For the purposes of this document, children with special hearing or communication needs may include, but are not limited to, children with permanent hearing impairment; or with severe or complex needs including:

- speech, language and communication difficulties
- visual impairments
- fluctuating hearing impairments caused by conductive hearing loss
- attention deficit hyperactivity disorders (ADHD)
- an auditory processing disorder or difficulty
- being on the autistic spectrum

The Equality Act 2010 places a duty on all schools and local authorities to prepare and implement accessibility strategies and plans to increase over time the accessibility of schools for disabled pupils and staff. Schools and local authorities are required to provide strategies for:

- a) increasing the extent to which disabled pupils can participate in a school's curriculum
- b) improving the physical environment of schools for the purpose of increasing the extent to which disabled pupils are able to take advantage of education and the benefits, facilities and services provided
- c) improving the delivery to disabled pupils of information that is readily accessible to pupils who are not disabled

This could mean provision of physical aids and acoustic improvements which would benefit hearing impaired and other pupils.

When alterations affect the acoustics of a space then improvement of the acoustics to promote better access for children with special needs, including hearing impairments, must be considered. Approved Document M: 2004 – 'Access to and Use of Buildings', in support of the Building Regulations [Ref.8](#) includes requirements for access for children with special needs. Other guidance includes BS 8300:2009 'Design of Buildings and their Approaches to Meet the Needs of Disabled People, Code of Practice' [Ref.9](#) and 'Acoustics of Schools: a Design Guide' [Ref.1](#).

In order to fulfil their duties under the Equality Act 2010, school client bodies should anticipate the needs of deaf and other disabled children as current and potential future users of the school.

Pupils with special educational needs are generally even more sensitive to the acoustic environment than others. Consequently, required reverberation times are shorter, sound insulation between adjacent spaces is higher and indoor ambient noise levels (and the capacity for distraction) lower than in environments for other pupils. This is reflected in the tables contained within this document.

Pupils with hearing impairment, autism and other special needs are often very sensitive to specific types of noise, particularly those with strong tonal, impulsive or intermittent characteristics. This should be taken into consideration in the design of areas which may be used by such children.

0.4.1. Special school accommodation and special units attached to mainstream schools

The acoustic design of all special school accommodation, and of alternative provision and special units attached to mainstream schools for pupils with special hearing and communication needs, should always involve an acoustician and in the case of pupils with hearing impairment an audiologist, as well as the school client body. The type of accommodation and approach to inclusion varies and must inform the design process.

The required acoustic conditions will depend on a pupil's individual special needs and may be accommodated by a specialist provision (eg a quiet room for private study and communication, or an assisted listening device for participation in general teaching), or by

improving the general acoustic conditions of teaching and learning spaces. Advice from a specialist acoustic consultant should be sought to allow the school client body to make an informed decision on the appropriate provision for the school's intended use.

The acoustic criteria for these types of accommodation should be signed off by the school client body in the same way as alternative performance standards (APS) as the particular needs of the pupils and the activities they take part in may vary widely from one school to another and within the same school.

The figures for rooms intended specifically for pupils with special hearing or communication needs in mainstream accommodation given in the tables in section 1 are a starting point and may not be suitable for the particular needs of the children in some types of accommodation.

0.5. Alternative performance standards

Alternative performance standards (APS) may be adopted for new buildings, where justified by specific educational, environmental, or health and safety requirements. An APS should not normally be of a lower standard than those shown for refurbishment in the tables given in section 1 or those described in the exceptions in section 1. Where the performance standard for refurbishment is proposed as an APS for a new school, a full and proper case must be made and documented to justify the decision.

Any APS must be justified by a suitably qualified acoustician and the school client body on the grounds of educational, environmental or health and safety need. The contractor, with the assistance of the project acoustician, should make the building control body and the client aware of the practical implications with respect to the operation of the space.

The procedure set out in section 2.2 must be followed and fully documented in the project's design risk register, building manuals or other documentation and this documentation should be made available to the school governors, staff and parents of pupils at the school, to ensure that the client and users of the school have the opportunity to understand the effect of any reduction in standards.

0.6. Surface spread of flame rating of acoustic linings and absorbers

Functional Requirement B2 of the Building Regulations controls the contribution that the surface linings of walls and ceilings will make to growth in the initial stages of fire. There are acoustic baffles and products available that have the necessary certification to comply with B2 and the need to provide certificates of conformity is part of the Building Regulations approval process.

Free hanging baffles are not part of the ceiling, but should have the appropriate spread of flame classification.

For further guidance see '[Building Bulletin 100](#)' ^{Ref.10} and '[Approved Document B](#)' ^{Ref.11}.

0.7. Durability and robustness

Where the physical behaviour of pupils requires a high level of robustness and durability from room finishes then due consideration should be given to the appropriate selection of materials in the acoustic design.

0.8. Acoustics and ventilation

The guidance on ventilation performance contained in the notes to table 2 in section 1.1.3 as it relates to the acoustics of schools supersedes the guidance in 'Building Bulletin 101: Design of Ventilation in Schools'. In due course BB101 will be revised in line with section 1.1.3.

1. Performance standards

The Building Regulations require that all spaces should meet the performance standards for indoor ambient noise level, airborne and impact sound insulation, and reverberation time as specified in tables 1 to 7. These values are for rooms that are finished, furnished for normal use, but unoccupied. Where rooms are to be used without furnishings, the performance standards normally apply in the empty condition. Normal furnishing is not anticipated to have any significant effect on indoor ambient noise levels or sound insulation, but may reduce measured reverberation times by providing diffusion and absorption.

The School Premises Regulations and the Independent School Standards also require that consideration be given to operational noise. To comply with the School Premises Regulations and the Independent School Standards open plan spaces should additionally meet the performance standards for speech transmission index in table 8. Guidance on the control of operational noise is provided in 'Acoustic Design of Schools: a Design Guide' [Ref.1](#).

Section 2 describes acoustic tests that can be used to demonstrate compliance with the in-situ performance standards in this section. It is strongly recommended that the client should require acoustic testing to be carried out as part of the building contract, because testing of the completed construction is the best practical means of ensuring that it achieves the design intent.

Further guidance is included in 'Acoustic Design of Schools: a Design Guide' [Ref.1](#). This provides additional information on the acoustic requirements and design of buildings for education purposes, on how to comply with these acoustic standards, and on testing / commissioning procedures.

The figures given in the tables for refurbishment should not normally be used for new build unless there are over-riding educational, environmental or health and safety reasons. The refurbishment standards are the minimum acceptable standard for Building Regulations compliance purposes for refurbishments to allow for difficulties of construction and buildings with a short residual life. However, where possible the target for refurbishment should be at least the new build standard where new elements of the building such as ceilings are installed during refurbishment. For example, there is considerable educational benefit in achieving the reverberation times for new build in refurbished teaching spaces.

There may also be considerable benefit in exceeding the Building Regulations standards for new build, for example music accommodation particularly where required for community use and third party lettings may need to be of a higher standard than that found in most schools. Overall the Building Regulations standards should be regarded as minimum standards and there is often considerable benefit in improving on them.

1.1. Indoor ambient noise levels in unoccupied spaces

1.1.1. Objectives and definitions

The objective is to provide suitable indoor ambient noise levels (IANL) for

- a) clear communication of speech between teacher and student
- b) clear communication between students
- c) learning and study activities

The IANL includes noise contributions from:

- external sources outside the school premises (including, but not limited to, noise from road, rail and air traffic, industrial and commercial premises)
- building services (eg, ventilation systems, plant, drainage etc). If a room is naturally ventilated, the IANL is calculated and measured with ventilators or windows open as required to provide ventilation as described in section 1.1.3. If a room is mechanically ventilated or cooled, the plant should be assumed to be running at its normal operating duty.
- actuator and damper noise - see [section 1.1.4](#)

The IANL excludes noise contributions from:

- teaching activities within the school premises, including noise from staff, students and equipment within the building or in the playground (noise transmitted from adjacent spaces is addressed by the airborne and impact sound insulation requirements)
- equipment used in the space (eg machine tools, CadCam machines, dust and fume extract equipment, compressors, computers, projectors, fume cupboards) as these noise sources are considered as operational noise, see 0.3.8
- rain noise - however, Building Regulation submissions should demonstrate that lightweight roofs and roof glazing have been designed to provide suitable control of rain noise reverberant sound pressure level in a space (calculated using laboratory test data with 'heavy' rain noise excitation as defined in BS EN ISO 140-18^[Ref.12]). Levels during heavy rain should not be more than 25 dB above the appropriate indoor ambient noise level given in table 1 (for refurbishments, this applies only to new roofing elements and not to repairs to existing roofs)

1.1.2. Acoustic performance standards

Table 1 specifies upper limits for indoor ambient noise levels in terms of $L_{Aeq,30mins}$ during normal teaching hours. Values for refurbishment are also the minimum acceptable standards for alternative performance standards in new buildings (see section 0.5).

Where a type of room is not listed, the nearest approximation should be used. Where a room is used for more than one purpose, the most onerous condition should be used.

Table 1: noise activity and sensitivity levels and upper limits for indoor ambient noise level

Type of room	Room classification for the purpose of airborne sound insulation in Tables 3a and 3b		Upper limit for the indoor ambient noise level $L_{Aeq,30mins}$ dB	
	Activity noise (Source room)	Noise tolerance (Receiving room)	New build	Refurbishment
Nursery school rooms <i>Primary school:</i> classroom, class base, general teaching area, small group room <i>Secondary school:</i> classroom, general teaching area, seminar room, tutorial room, language laboratory	Average	Medium	35	40
<i>Open plan:</i> (See also section 1.8) Teaching area Resource/breakout area	Average	Medium	40	45
Primary music room	High	Medium	35	40
Secondary music classroom ¹ Small and large practice/group room ¹ Performance/recital room ¹	Very high	Low	35	40
Performance/recital room ¹ Ensemble room ¹ Recording studio ¹	Very high	Low	30	35
Control room - for recording ¹ Control room - not for recording	High Average	Low Medium	35	40
Lecture room	Average	Medium	35	40
Teaching space intended specifically for students with special hearing and communication needs ²	Average	Low	30	35
SEN calming room	High	Low	35	35

Type of room	Room classification for the purpose of airborne sound insulation in Tables 3a and 3b		Upper limit for the indoor ambient noise level $L_{Aeq,30mins}$ dB	
	Activity noise (Source room)	Noise tolerance (Receiving room)	New build	Refurbishment
Study room (individual study, withdrawal, remedial work, teacher preparation)	Low	Medium	40	45
<i>Libraries:</i>				
Quiet study area	Low	Medium	40	45
Resource area	Average	Medium	40	45
Science laboratory	Average	Medium	40	45
<i>Design and technology:</i>				
Resistant materials, CAD/CAM area	High	High	40	45
Electronics/control, textiles, food, graphics, design/resource area, ICT room, art	Average	Medium	40	45
Drama studio, assembly hall, multi-purpose hall (drama, PE, audio/visual presentations, assembly, occasional music)	High	Low	35	40
Atrium, circulation space not intended for teaching and learning	Average	Medium	45	50
Sports hall				
Dance studio	High	Medium	40	45
Gymnasium/Activity studio				
Swimming pool	High	High	50	55
Meeting room, Interviewing/counselling room, video conference room	Low	Medium	40	45
Dining room	High	High	45	50

Type of room	Room classification for the purpose of airborne sound insulation in Tables 3a and 3b		Upper limit for the indoor ambient noise level $L_{Aeq,30mins}$ dB	
	Activity noise (Source room)	Noise tolerance (Receiving room)	New build	Refurbishment
<i>Administration and ancillary spaces:</i>				
Kitchen	High	High	50	55
Office, medical room, staff room	Low	Medium	40	45
Corridor, stairwell, coats and locker area	Average	High	45	55
Changing area	High	High	50	55
Toilet	Average	High	50	55

Notes

¹ Music rooms – the levels of sound insulation between some music rooms may not be sufficient for particularly noisy activities and timetabling/management will need to be considered. Wherever possible music accommodation should make use of buffer spaces such as stores to increase the levels of sound insulation between rooms and to isolate rooms where very noisy activities such as drum practice will take place. If timetabling/management or isolation is not possible the levels of sound insulation should be increased. For further guidance on the design of music accommodation see ‘Music Accommodation in Secondary Schools: a Design Guide’, DfE, NBS/RIBA, 2010 [Ref.13](#) and ‘Acoustics of Schools: a design guide’ [Ref1](#)

² APSs are commonly required for these rooms and should be agreed by an acoustician and the school client body. See section 0.4.

In order to protect students from regular discrete noise events, eg, aircraft or trains, indoor ambient noise levels should not exceed 60 dB $L_{A1, 30mins}$. This is achieved by default for spaces with IANLs up to 40 dB $L_{Aeq, 30min}$, but requires assessment in spaces with higher IANL limits, eg, 45 and 50 dB.

1.1.3. Building services and indoor ambient noise levels

Noise from building services under normal conditions should meet the limits for indoor ambient noise levels (IANL) given in table 1.

The design should show that IANLs can be achieved when the ventilation systems are operating in their normal condition; when providing intermittent boost ventilation; and when operating to control summertime overheating. A ventilation strategy may use one type of system for normal operation, and different types of system for intermittent boost and summertime overheating. The tolerances on the IANL limits in Table 1 for different types of ventilation system under different operating conditions are summarised in Table 2 below.

Table 2: summary of ventilation condition, system type and associated IANL tolerance

Condition	Ventilation system	Noise level limit
Normal - ventilation for normal teaching and learning activities	Mechanical ¹	Table 1 value
	Natural ²	Table 1 value + 5 dB ⁴
	Hybrid ²	Mechanical system noise: Table 1 value
		Total noise level: Table 1 value + 5 dB
Summertime ⁵ - ventilation under local control of teacher to prevent overheating – allowable during the hottest 200 hrs of the year	Mechanical	Table 1 value + 5 dB ⁴
	Natural or Hybrid	≤55 dB
Intermittent boost ⁶ – ventilation under local control of teacher for dilution of fumes during practical activities as in practical spaces for science, art, food technology and design and technology	Mechanical	Table 1 value + 5 dB ⁴
	Natural	≤55 dB
Process - extract ³ can be automatic ventilation for safety and/or under local control of teacher	Mechanical and/or natural	See IoA/ANC guide ^{Ref1} for operational noise levels

Notes

¹ The normal condition for a ventilation system with purely mechanical air supply is defined as when the system is operating to limit the daily average carbon dioxide concentration to no more than 1,000ppm with the maximum concentration not exceeding 1,500ppm for more than 20 consecutive minutes on any day during normal school operating hours. This would normally equate to a minimum ventilation rate of approximately 8l/s per person. Mechanical ventilation in this context refers to systems (or parts of systems) that use mechanical fans to mix or drive the air including those in mechanical, hybrid, mixed mode and natural ventilation systems and in fan convector heaters.

² The normal condition for a ventilation system in natural or hybrid mode is defined as when the system is operating to limit the daily average carbon dioxide concentration to no more than 1,500ppm with the maximum concentration not exceeding 2,000ppm for more than 20 consecutive minutes on any day. This would normally equate to a minimum ventilation rate of approximately 5l/s per person. For hybrid systems, the mechanical noise excluding external noise break in, should meet the IANL figure in table 1.

The mid-season design condition can be used in simple ventilation calculations and is defined as an outside temperature of 11 °C and an internal air temperature of 20 °C with no external wind effect.

Where external ambient free field noise levels at the facade expressed as the LAeq,30mins, do not exceed the IANL figures given in Table 1 by more than 16 dB for single sided ventilated spaces and 20 dB for cross ventilated or roof ventilated spaces, the criteria for natural ventilation can usually be achieved. However, the ventilation strategy still requires appropriate design of façade openings, height differences between low and high level openings, corridor transfer vents/stacks, etc, to limit the required façade open areas appropriately.

Where there is a hybrid system, any mechanical system components should meet the IANL limits from table 1. The total noise level including external noise ingress may exceed the IANL limit from table 1 by up to 5 dB.

³ Process extract includes the operational noise from local exhaust ventilation systems and boost ventilation under the local control of the teacher as required for fume and dust extract in design and technology, odour and steam from cookers in food technology, fume cupboard extract and similar process extract systems. See guidance on specification and measurement of operational noise levels in 'Acoustics of Schools: a design guide' [Ref.1](#). For example, for new fume cupboards the maximum noise level should not exceed 50 dB(A), measured at a height of 1,500 mm above the floor and 1,500 mm from the face of the fume cupboard, with the sash set at a height of 200 mm.

⁴ The +5 dB does not apply to teaching and learning spaces where the Table 1 IANL is greater than or equal to 45 dB.

⁵ Natural, mechanical or hybrid ventilation systems may be used to improve thermal comfort in summer at the expense of higher indoor ambient noise levels. The normal ventilation IANL can be exceeded during the hottest 200 hours in peak summertime conditions and the design should show that IANLs, defined in table 3 can be met under these conditions as well as under normal operation. The ventilation must be under the local control of the teacher so that the noise level can be reduced to normal levels when needed. This does not apply to classrooms intended specifically for students with special hearing and communication needs, or to speech therapy rooms.

The peak summertime condition is defined as the 200 hottest hours that occur using the design summer year (DSY) weather file during normal daily school operating hours including the summer holiday period. Thermal modelling and assessment of acoustic performance should be carried out as if the school were occupied through the summer holiday period. This corresponds to a much lower number of hours during normal term time (equivalent to typically 40 teaching hours in a school year) as most of the hottest hours occur during the holiday period.

⁶ The noise level from locally controlled intermittent boost mechanical ventilation may exceed the IANL by up to 5 dB.

Figures 1, 2 and 3 below illustrate the various conditions, ventilation systems and associated noise levels as described in Table 2.

Figure 1: combined mechanical noise and external noise break-in – natural and hybrid/mixed mode systems (mechanical noise excludes noise from process extract fans)

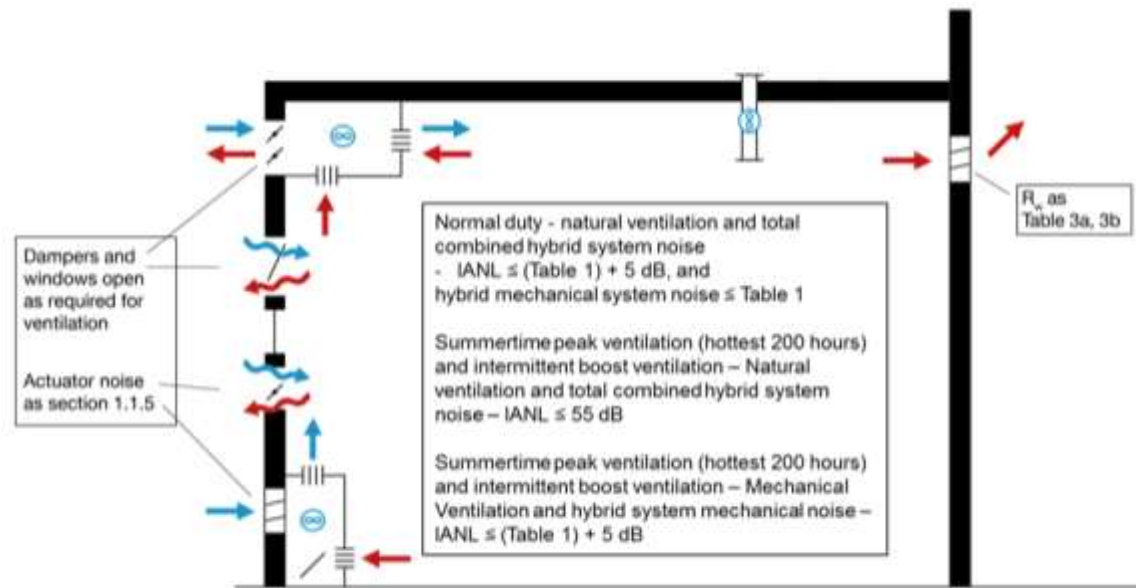

Figure 2: mechanically generated noise levels – mechanical and hybrid/mixed mode systems (excludes external noise break-in and noise from process extract)

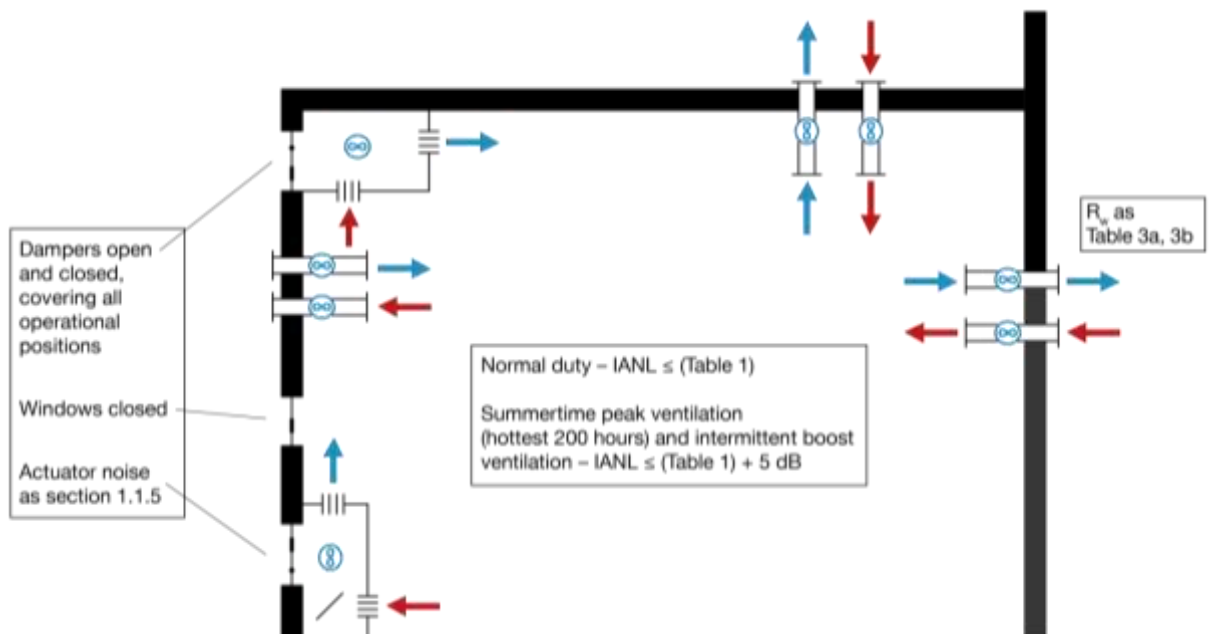
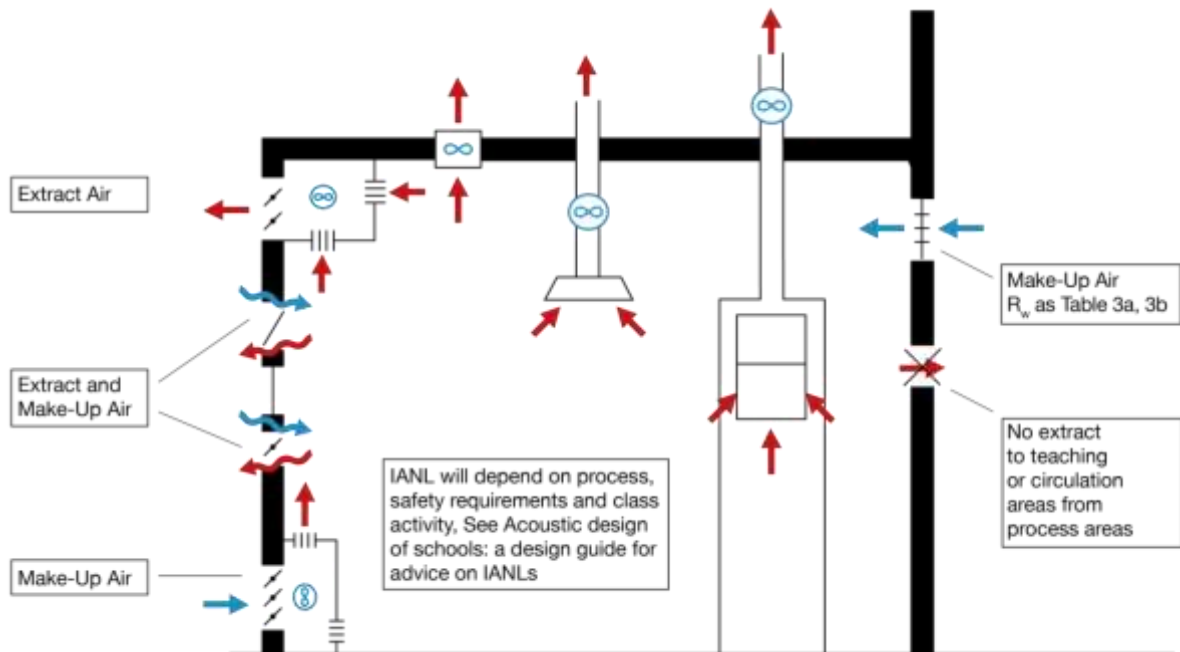

Figure 3: process extract and exhaust ventilation for heat, pollutants, and gas safety



1.1.4. Noise from ventilator actuators and dampers

Relatively low noise levels can be disruptive to class activities where automatic systems are not under user control. In order to comply with the requirements of the Building Regulations, the noise from the normal operation of automatic systems measured in accordance with ISO 16032 in terms of $L_{Aeq,t}$ ¹ should be no more than 5 dB above the IANL specified for the space. The window frame may also have an effect on the noise emitted, and is to be included in the assessment of this noise. However as there is not currently sufficient design data to predict in-situ levels accurately, an assessment based on measurement of a reference installation² may be used until further guidance is provided.

Guidance on using ISO 16032 to assess the noise from window actuators and reference actuator installations is given in 'Acoustics of Schools: a Design Guide' [Ref1](#).

¹ $L_{Aeq,t}$ the integration period, t, is the duration of a normal operating cycle and the actuator should be operating throughout the measurement.

² For the reference installation $L_{Aeq,n}$ as defined in ISO 16032 should be measured and the assessment should compare the proposed installation with the reference installation.

1.2. Airborne sound insulation between spaces

1.2.1. Objectives and definitions

The objective is to attenuate airborne sound transmitted between spaces. The effect of internal glazing, doors, structure-borne and flanking transmission on sound transmission must be considered.

The sound insulation is assessed in terms of the standardised level difference D_{nT} in accordance with BS EN ISO 16283-1 and the results are weighted and expressed as a single-number quantity, $D_{nT,w}$ in accordance with BS EN ISO 717-1. For the purposes of the assessment the reference reverberation time T may be either:

- the upper limit for the mid-frequency reverberation time, $T_{mf,max}$ for the receiving room type (see table 6) applied to all one-third octave bands from 100 Hz to 3.15 kHz;

or, for commissioning measurements:

- the measured reverberation time in each third octave band, provided that the mid-frequency reverberation time, T_{mf} , complies with the requirements in table 6 and is representative of the reverberation times expected when the room is finished and unfurnished.

1.2.2. Acoustic performance standards

Tables 3a and 3b show the minimum standards for airborne sound insulation required between rooms. These values are defined by the activity noise in the source room and the noise tolerance in the receiving room as given in table 1. Table 3b is for conversions and refurbishments of existing buildings, and values are also the minimum acceptable standards for alternative performance standards in new buildings (see section 0.5).

The design assessment of $D_{nT,w}$ between 2 rooms should be carried out in both directions.

Table 3a: new build performance standards for airborne sound insulation between spaces

Minimum $D_{nT,w}$ (dB)		Activity noise in source room (see Table 1)			
		Low	Average	High	Very high
Noise tolerance in receiving room (see Table 1)	High	Not applicable	35	45	50
	Medium	40	45	50	55
	Low	45	50	55	55

Table 3b: refurbishment performance standards for airborne sound insulation between spaces

Minimum $D_{nT,w}$ (dB)		Activity noise in source room (see Table 1)			
		Low	Average	High	Very high
Noise tolerance in receiving room (see Table 1)	High	Not applicable	30	35	45
	Medium	30	40	45	45
	Low	35	40	50	50

1.2.3. Exceptions

- a) Serving hatches between kitchens and multi-purpose halls used for dining should be avoided where practicable, and serveries placed between kitchens and dining areas wherever possible to avoid noise transfer during meal preparation. Where this is not possible, serving hatches should be designed to have as high a level of sound insulation as practicable (not less than 18 dB R_w) and, if necessary, use of the dining hall space timetabled so that noise sensitive activities, eg exams, do not take place in the hall when the kitchen is in use. Where the space is used solely for dining purposes, a sound insulated serving hatch between kitchen and dining space is not necessary.
- b) Where it is essential to link a teaching space with another occupied room via an interconnecting door for operational or safety purposes, a doorset should be used with a rating of at least 35 dB R_w . The surrounding wall (including any glazing) should have a composite sound insulation rating of at least 45 dB R_w . Where there is an operable wall or folding partition between a teaching area and a hall, the $D_{nT,w}$ between the spaces should be at least 40 dB. The end user should be made aware that the sound insulation performance of the operable wall may not facilitate simultaneous independent use of the spaces on either side
- c) Vision panels between multi-purpose halls, music rooms and control rooms require careful consideration. If visual communication only is required then the vision panel should provide at least 45 dB R_w , set within a wall rated at 55 dB R_w . This degree of sound insulation from a vision panel will require specialist design input. Where visual and audio communication is required between the spaces then a sliding vision panel of only nominal acoustic performance may be appropriate, set in a wall rated at 45 dB R_w

1.3. Airborne sound insulation between circulation spaces and other spaces used by students

1.3.1. Objectives and definitions

The objective is to attenuate airborne sound transmitted between circulation spaces (eg corridors, stairwells etc) and other spaces used by students, for the purposes of minimising

disturbance to teaching and learning spaces. This applies where the separating construction contains doors and/or glazed elements. Where a partition both separates a circulation space, and also separates 2 teaching and learning spaces, values from table 3a or table 3b should be used for the element of the partition separating 2 teaching and learning spaces.

Values in tables 4a and 4b are the minimum weighted sound reduction index R_w of doorsets and the minimum composite weighted sound reduction index of wall and glazing (with and without ventilators). The weighted sound reduction index is measured in accordance with BS EN ISO 140-3 and rated in accordance with BS EN ISO 717-1.

The sound insulation of ventilators is specified in terms of the weighted element-normalised level difference, $D_{n,e,w} - 10 \lg N$, where N is the number of ventilators with airborne sound insulation $D_{n,e,w}$. The weighted element-normalised level difference is measured in accordance with BS EN ISO 10140-10 and rated in accordance with BS EN ISO 717-1.

1.3.2. Acoustic performance standards

Performance standards for airborne sound insulation between circulation spaces and other spaces used by students

Table 4a shows the minimum permissible airborne sound insulation for a composite separating wall construction, for a separating wall that does not include ventilators in the wall. Values for refurbishment are also the minimum acceptable standards for alternative performance standards in new buildings (see section 0.5).

Table 4a: performance standards for airborne sound insulation between circulation spaces and other spaces used by students, with no ventilator in the wall

Type of space used by students	Minimum R_w dB		
	Composite R_w of wall and glazing with no ventilator		Doorset
	New build	Refurbishment	
Secondary school music room Control room – for recording Drama room Multi-purpose hall Teaching space intended specifically for use by students with special hearing or communication needs	45	40	35
Primary music classroom All other rooms used for teaching or learning	40	35	30

Table 4b shows the minimum permissible airborne sound insulation for a separating wall that includes ventilators in the wall. Values for refurbishment are also the minimum acceptable standards for alternative performance standards in new buildings (see section 0.5).

Table 4b: performance standards for airborne sound insulation between circulation spaces and other spaces used by students, with ventilators in the wall

Type of space used by students	Minimum R_w dB			Alternative to composite R_w of wall, glazing and ventilators dB, provided values in Table 3a are provided by wall, glazing and doors
	Composite R_w of wall, glazing and ventilators dB		Doorset	Minimum $D_{n,e,w} - 10 \lg N$ dB for ventilators
	New build	Refurbishment		
Secondary school music room Control room – for recording Drama room Multi-purpose hall Teaching spaces intended specifically for use by students with special hearing or communication needs	38	35	35	37
Primary music classroom All other rooms used for teaching or learning	33	30	30	32

1.4. Impact sound insulation of floors

1.4.1. Objectives and definitions

The objective is to control impact sound (eg from footsteps and movement of furniture) transmitted into spaces via the floor above. It does not therefore address issues such as slamming doors (where care should be taken to ensure doors are fitted with soft closers

wherever possible) or significant impacts such as dancing (where specialist advice will be required from the acoustician and structural engineer).

Values in the tables are the maximum permissible weighted standardised impact sound pressure level $L'_{nT,w}$ dB. This is measured in accordance with BS EN ISO 140-7 and rated in accordance with BS EN ISO 717-2.

For the purposes of the assessment the reference reverberation time T may be either:

- the upper limit for the mid-frequency reverberation time, $T_{mf,max}$ for the receiving room type (see Table 6) applied to all one-third octave bands from 100 Hz to 3.15 kHz;

or, for commissioning measurements:

- the measured reverberation time in each third octave band, provided that the mid-frequency reverberation time, T_{mf} , complies with the requirements in Table 6 and is representative of the reverberation times expected when the room is finished and unfurnished.

1.4.2. Acoustic performance standards

Table 5 shows the maximum weighted standardised impact sound pressure level, $L'_{nT,w}$ for receiving rooms of different types and uses. Values refurbishment are also the minimum acceptable standards for alternative performance standards in new buildings (see section 0.5).

Table 5: performance standards for impact sound insulation of floors

Type of room (receiving room)	Maximum impact sound pressure level $L'_{nT,w}$ dB	
	New build	Refurbishment
Teaching space intended specifically for students with special hearing or communication needs (See Section 0.4)	55	60
<i>Music:</i> Secondary music room Small and large practice/group room Ensemble room Performance/recital room Recording studio Control room - for recording Control room – not for recording	55	60

Type of room (receiving room)	Maximum impact sound pressure level $L'_{nT,w}$ dB	
	New build	Refurbishment
Nursery school room <i>Primary school:</i> classroom, music classroom, class base, general teaching area, small group room <i>Secondary school:</i> classroom, general teaching area, seminar room, tutorial room, language laboratory Open plan teaching and resource area Library Lecture room Science laboratory Drama studio Design and technology - resistant materials, CadCam area, electronics/control, textiles, food, graphics, design/resource area, ICT room, art room, Assembly hall, multi-purpose hall (drama, PE, audio/visual presentations, assembly, occasional music) Sports hall Gymnasium/Activity studio Dance studio Meeting room, interviewing/counselling room, video conference room SEN calming room	60	65
Atrium, circulation not teaching and learning Swimming pool Dining room <i>Administration and ancillary spaces:</i> Kitchen Office, staff room, medical room Corridor, stairwell Coats and locker area and changing area Toilet	65	65

1.4.3. Exceptions

It is usual under Building Regulations for impact criteria to be achieved by the structural floor without finishes. However, as floor finishes in schools are usually fixed they may be taken into account in the design.

1.5. Reverberation in teaching and study spaces

1.5.1. Objectives and definitions

The objective is to provide suitable reverberation times (RTs) for:

- clear communication of speech between teacher and student
- clear communication between students
- music teaching and performance

The reverberation time in table 6 is quoted in terms of the mid-frequency reverberation time, T_{mf} which is the arithmetic average of the reverberation times in the 500 Hz, 1 kHz and 2 kHz octave bands, or the arithmetic average of the reverberation times in the one-third octave bands from 400 Hz to 2.5 kHz. (Although these are not mathematically equivalent, in practice the difference will be small and in the interests of simplicity and ease of measurement, either is acceptable).

For teaching spaces for use by students with special hearing or communication needs, the required reverberation time is expressed as the arithmetic average of the reverberation times in the 125 Hz to the 4 kHz octave bands, or the arithmetic average of the reverberation times in the one-third octave bands from 100 Hz to 5 kHz.

These values are for rooms that are finished, furnished for normal use, but unoccupied.

1.5.2. Acoustic performance standards

Table 6 contains the maximum mid-frequency reverberation time requirements. Values for refurbishment are also the minimum acceptable standards for alternative performance standards in new buildings (see section 0.5).

Table 6: performance standards for reverberation time

Type of room	T_{mf} seconds	
	New build	Refurbishment
Nursery school room <i>Primary school:</i> classroom, class base, general teaching area, small group room, SEN calming room	≤ 0.6	≤ 0.8
<i>Secondary school:</i> classroom, general teaching area, seminar room, tutorial room, language laboratory Study room (individual study, withdrawal, remedial work, teacher preparation) Science laboratory Design and technology: Resistant materials, CAD/CAM area, Electronics/control, textiles, food, graphics, design/resource area, ICT room, art	≤ 0.8	≤ 1.0
<i>Open plan:</i> Teaching area Resource/Breakout area	≤ 0.5 [see section 1.8] ≤ 1.2 [see section 1.8]	≤ 0.5 [see section 1.8] ≤ 1.2 [see section 1.8]
<i>Music:</i> Primary music room Secondary music classroom Practice/group room, volume ≤ 30 m ³ Practice/group room, volume > 30 m ³ Ensemble room, Live room Performance/recital room Control room - for recording Control room - not for recording	≤ 1.0 ≤ 1.0 ≤ 0.6 ≤ 0.8 0.6 - 1.2 ¹ 1.0 - 1.5 ≤ 0.5 ≤ 0.5	≤ 1.0 ≤ 1.0 ≤ 0.8 ≤ 1.0 0.6 - 1.2 ¹ 1.0 - 1.5 ≤ 0.6 ≤ 0.6
<i>Lecture rooms:</i> Small (fewer than 50 people) Large (more than 50 people)	≤ 0.8 ≤ 1.0	≤ 1.0 ≤ 1.0
Teaching space intended specifically for students with special hearing or communication needs (See Section 0.4)	$T \leq 0.4$ averaged from 125 Hz to 4kHz octave band centre frequencies and $T \leq 0.6$ s in every octave band in this range. ²	≤ 0.4. ²
Library	≤ 1.0	≤ 1.2

Type of room	T_{mf} seconds	
	New build	Refurbishment
Drama studio	≤ 1.0	≤ 1.0
Atrium, foyer, entrance hall, circulation space not used for teaching and learning	≤ 1.5	≤ 2.0
Assembly hall, multi-purpose hall (drama, PE, audio/visual presentation, assembly, occasional music),	0.8- 1.2 ¹	0.8 - 1.5 ¹
Indoor sports hall, swimming pool	$\leq (1.5 - 2.0)$ dependant on size of space. See section 1.6.2	≤ 2.0
Gymnasium/activity studio	≤ 1.5	≤ 2.0
Dance studio	≤ 1.2	≤ 1.5
Meeting room, Interviewing/counselling room, video conference room	≤ 0.8	≤ 0.8
Dining room	≤ 1.0	≤ 1.5
<i>Administration and ancillary spaces</i>		
Kitchen	≤ 1.5	≤ 2.0
Office, medical room, staff room	≤ 1.0	≤ 1.2
Corridor, stairwell	See section 1.7	See section 1.7
Coats and locker area, changing area	≤ 1.5	≤ 2.0
Toilet	≤ 1.5	≤ 2.0

Notes

¹ Reverberation time should be within the indicated range, including the values given.

² APSs are commonly required for these rooms and should be agreed by an acoustician and the school client body. See section 0.4.

1.6. Reverberation and acoustic absorption in sports halls and swimming pools

1.6.1. Objectives and definitions

The objective is to provide suitable reverberation times (RTs) for:

- clear communication of speech between teacher and student
- clear communication between students

The reverberation time is quoted in terms of the mid-frequency reverberation time, T_{mf} , which is the arithmetic average of the reverberation times in the 500 Hz, 1 kHz and 2 kHz octave bands, or the arithmetic average of the reverberation times in the one-third octave bands from 400 Hz to 2.5 kHz. For sports halls specifically for use by students with special hearing or communication needs, the reverberation time is specified as the arithmetic average of the reverberation times in the 125 Hz to the 4 kHz octave bands, or the arithmetic average of the reverberation times in the one-third octave bands from 100 Hz to 5 kHz.

1.6.2. Acoustic performance standards

The maximum Reverberation Time for sports halls reduces from 2 seconds for halls of floor area greater than 530 m² to 1.5 seconds for sports halls of floor area less than 280 m² floor as shown in Table 7.

Table 7: performance standards for sports halls T_{mf} as a function of floor area

Floor area	Maximum T_{mf} seconds
<280 m ²	1.5
280-530 m ²	$2.0 \times [1 - (530 - \text{Floor area}) / 500]$
>530 m ²	2.0

1.6.3. Demonstrating compliance

For sports halls, swimming pools, gymnasias, dance studios and other normally unfurnished activity spaces, compliance with the reverberation time criterion given in table 6 may be demonstrated either by execution of a design in accordance with the 'Acoustics of Schools: a Design Guide' [Ref.1](#), or measurement of the mid-frequency reverberation time in accordance with the Association of Noise Consultants 'Good Practice Guide – Acoustic Testing of Schools' [Ref.7](#).

1.7. Sound absorption in corridors and stairwells

1.7.1. Objectives and definitions

The objective is to absorb sound in corridors, entrance halls and stairwells so that it does not interfere with teaching and study activities in adjacent rooms.

The amount of absorption required should be calculated according to Approved Document E, section 7 [Ref.3](#). This describes 2 calculation methods, A and B, for controlling reverberation in the common internal parts of domestic buildings. Either of these methods can be used to determine the amount of absorption required in corridors, entrance halls and stairwells in schools.

1.8. Open plan teaching and learning

In order to comply with Requirement E4 of the Building Regulations it is necessary to consider indoor ambient noise level and reverberation in open plan spaces, and sound insulation from open plan units to other adjacent spaces. STI criteria in open plan spaces are not included in the normal means of satisfying Requirement E4 of the Building Regulations.

In order to comply with the School Premises Regulations, the Independent School Standards and the Equality Act, it is necessary to consider the speech transmission index (STI) in open plan spaces (both new build and refurbishments), and it is strongly recommended that STI criteria for open plan accommodation are incorporated as a contractual requirement within the employer's requirements/design brief.

It is also strongly recommended that school client bodies obtain specialist independent advice from a suitably qualified acoustic technical adviser in order to ensure that the proposed design and associated 3D acoustic model achieves compliance with the required STI criteria. For enclosed teaching and study spaces it is possible to achieve good speech intelligibility through specification of the indoor ambient noise level, sound insulation and reverberation time. Open plan spaces require additional specification as they are significantly more complex acoustic spaces. The main issue is that intrusive noise arising from activities in adjacent learning areas and circulation spaces significantly increases the background noise level, which in turn decreases speech intelligibility and can cause distraction. Occupants working and talking within the space tend to raise their vocal effort as the background noise level increases, resulting in a spiralling increase in noise levels. This can be reduced, but not eliminated, by the provision of large amounts of acoustic absorption.

Open plan teaching and learning spaces should not be regarded as a simple alternative to traditional classrooms, and may be unsuitable for some children, particularly those with special hearing or communication needs. In order to fulfil their duties under the Equality Act 2010, school client bodies should anticipate the needs of deaf and other disabled children as current and potential future users of the space when open plan accommodation is being considered.

1.8.1. Objectives and definitions

The objective is to control the build-up of occupancy noise, provide clear communication of speech within teaching groups, and provide sufficient speech privacy between teaching groups.

The expected open plan layout and activity plan should be agreed with the client at an early stage of the design as the basis on which compliance with the speech transmission index (STI) performance standard can be demonstrated.

An activity management plan should be documented and used to establish (via a computer prediction model) the overall noise level due to all activities in the open plan space.

1.8.2. Acoustic performance standards

Table 8 gives the performance criteria for open plan spaces, to be achieved in conjunction with the values given in other tables.

Table 8: Performance standards for speech intelligibility and privacy in open plan spaces – speech transmission index (STI)

Condition	Speech transmission index (STI)
Instruction or critical listening activity – within group	$\geq 0.6^1$
Between groups (during critical listening activities)	≤ 0.3

¹ A higher STI value may be more appropriate for students with special hearing or communication needs. Refer to 'Acoustic design of schools: a design guide' [Ref.1](#) for further details.

The required IANLs in Table 1 and the T_{mf} s in table 6 for open plan teaching and break-out areas act as a safeguard against inadequate levels of acoustic absorption in open plan areas enforced through the Building Regulations. However to comply with the School Premises Regulations, STI calculations are required for these spaces to enable design solutions with more precise placing of absorption, diffusion and screening to ensure verification of intelligibility performance in accordance with a specific activity plan.

'Acoustics of Schools: a Design Guide' [Ref.1](#) contains a risk matrix for open plan design and further guidance for schools and designers. The risk matrix should be used at the early design stage when open plan spaces are considered.

For moderate and high risk open plan arrangements as identified by the risk matrix it is essential to carry out STI modelling of the open plan spaces.

STI should be calculated in accordance with EN 60268-16 [Ref.14](#).

A computer prediction model should be used to calculate the STI in the open plan space. The background noise level used in the STI calculation should be the overall occupancy noise level (established from a prior computer prediction model) for the expected open plan layout and activity management plan (see section 1.8.4). The background noise level is the overall noise level due to all activities in the open plan space (including teaching and study from adjacent classbases, but excluding the relevant speech signal).

The computer prediction software used for this process should be capable of simulating an impulse response and should have been verified previously for this type of calculation. In general this type of software requires considerable expertise in room acoustics. The software should be used to create a three-dimensional geometric model of the space, comprising surface materials with scattering coefficients and sound absorption coefficients for each relevant octave frequency band. The model should allow for the location and

orientation of single and multiple sources with user-defined sound power levels and directivity. See 'Acoustics of Schools: a Design Guide' [Ref.1](#) for further details.

1.8.3. Exceptions

In some instances, open plan designs may not be intended for critical listening activities, or multiple and simultaneous independent instruction. For example, critical listening activity may only occur as a single, plenary session (ie having negligible intrusive noise from adjacent areas), followed by break-out activity sessions. These break-out sessions may only involve less critical personal listening activities (eg one-to-one or small group instruction, paired or small group work) or individual study. In this case it is necessary to demonstrate STI compliance for the plenary session only, provided that the reverberation time target given in table 6 is also achieved. Refer to 'Acoustics of Schools: a Design Guide' [Ref.1](#) for further details.

1.8.4. Demonstrating compliance

The designer should clearly demonstrate how the open plan space will meet the criteria contained in table 7, by means of layout plans, activity management plans, and a corresponding 3D acoustic model to predict STI criteria. Refer to 'Acoustics of Schools: a Design Guide' [Ref.1](#) for further details.

These need to be formally agreed by the school client body as they are responsible under the School Premises Regulations for ensuring that speech intelligibility in open plan teaching areas is suitable for the intended educational use of the spaces.

It is strongly recommended that the school client body obtains specialist independent advice from a suitably qualified acoustic technical adviser in order to ensure that the proposed design and corresponding 3D acoustic model accurately predicts the required STI criteria, and that the management plan presents a low risk of noise conflict or incompatibility with the educational vision.

2. Compliance

2.1. Procedures

Prior to construction, intention to comply with Building Regulations on acoustics is demonstrated through submission to the building control body of a set of plans, construction details, material specifications, and calculations, as appropriate for each area of the school that is covered by Requirement E4 of the Building Regulations.

There is no requirement in Building Regulations for acoustic commissioning of schools although it is strongly recommended for contractual purposes.

The school client body is required to approve alternative performance standards and open plan designs (see sections 0.4, 0.5 and 1.8).

2.2. Alternative performance standards

In some circumstances alternative performance standards may be appropriate for specific areas within individual schools for particular educational, environmental or health and safety reasons (see section 0.5). In these cases, the following information should be provided to the building control body:

- a written report by a specialist acoustic consultant clearly identifying (a) all areas of non-compliance with the performance standards (b) the proposed alternative performance standards and (c) the technical basis upon which these alternative performance standards have been chosen
- written confirmation from the school client body of areas of non-compliance, together with the justification for the need and suitability of the APS in each space

2.3. Acoustic commissioning

Pre-completion testing and subsequent reporting should be carried out by a specialist acoustic consultant in accordance with the testing and reporting procedures described in the Association of Noise Consultants publication 'Good Practice Guide – Acoustic Testing of Schools'. [Ref.7](#)

References

1. 'Acoustics of Schools: a design guide', to be published in 2015 by the Association of Noise Consultants and the Institute of Acoustics
2. [Building Bulletin 93, 'The Acoustic Design of Schools'](#), 2003, DfES. ISBN 0 11 271105 7
3. Approved Document E – '[Resistance to the passage of sound](#)'. 2010. ISBN 978 1 85946 204 1
4. Statutory Instrument: No.1943 '[The Education \(School Premises\) Regulations 2012, Education England and Wales](#)', ISBN 978 0 11 152768 9
5. Statutory Instrument No.2962 '[The Education \(Independent School\) Standards \(England\) \(Amendment\) Regulations](#)' 2012. ISBN 978 0 11 153129 7. A [consolidated version of the regulations showing the 2012 revisions](#) is also available
6. '[The Equality Act 2010: advice for schools](#)'. DfE departmental advice for school leaders, school staff, governing bodies and local authorities. DFE-00296-2013
7. Association of Noise Consultants, '[Good Practice Guide – Acoustic Testing of Schools](#)', 2011
8. Approved Document M: 2010 '[Access to and use of buildings](#)', in support of the [Building Regulations](#), ISBN 978 1 85946 211 9
9. BS 8300: 2009, '[Design of buildings and their approaches to meet the needs of disabled people](#)'. Code of practice. ISBN 978 0 580 70730 8
10. Building Bulletin 100, '[Design for fire safety in schools](#)', DCSF, 2007. ISBN 978 1 85946 291 1, NBS/RIBA
11. Approved Document B: 2013 '[Fire Safety: Volume 2 – Buildings other than dwelling houses](#)', in support of the [Building Regulations](#), ISBN 978 1 85946 489 2
12. BS EN ISO 140-18 '[Acoustics – Measurement of sound insulation in buildings and of building elements – Part 18](#): Laboratory measurement of sound generated by rainfall on building element'
13. 'Music Accommodation in Secondary Schools, a design guide', DfE, NBS/RIBA, 2010
14. BS EN 60268-16: 2011 '[Sound system equipment – Part 16](#): Objective rating of speech intelligibility by speech transmission index'

Further information

Useful resources and external organisations

- [Association of Noise Consultants](#)
- [Institute of Acoustics](#)
- [BATOD](#)
- [BAEA](#)

Other relevant departmental advice and statutory guidance

- [Standards for school premises](#)

Other departmental resources

- [Tools and supporting information on acoustic design are available on GOV.UK](#)



Department
for Education



Education
Funding
Agency

© Crown copyright 2014

You may re-use this document/publication (not including logos) free of charge in any format or medium, under the terms of the Open Government Licence v3.0. Where we have identified any third party copyright information you will need to obtain permission from the copyright holders concerned.

To view this licence:

visit www.nationalarchives.gov.uk/doc/open-government-licence/version/3

email psi@nationalarchives.gsi.gov.uk

About this publication:

enquiries www.education.gov.uk/contactus

download www.gov.uk/government/publications

Reference: BB93



Follow us on Twitter:
[@educationgovuk](https://twitter.com/educationgovuk)



Like us on Facebook:
facebook.com/educationgovuk